

modular motion control

SYSTEM-90E

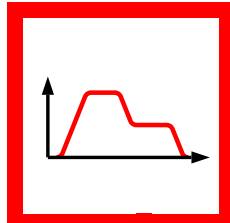

This motion control module serves to control servo motors equipped with an absolute encoder with EnDat 2.1 interface.

Within a control system, this module can be randomly combined with other motion control and axis modules to create multi-axis topologies, whereby setting parameters for and programming of the respective axes is identical.



Together with a servo power module, this module is especially suitable for ultra-precision driving of rotational direct drives, torque motors and AC servo motors.



MCE-8

Motion control module for absolute encoders with EnDat 2.1 interface

- High-resolution position detection using an absolute encoder with EnDat 2.1 interface and additional sinusoidal incremental signals
- Optimum motion design with defined acceleration and jerk control
- Setting of parameters and performing diagnosis are made easy by following fully digitalized routines
- Can be combined with servo power modules for driving motors with a power rating of up to 11 kW
- Direct connection of a servo power module via the uniform pLINK interface

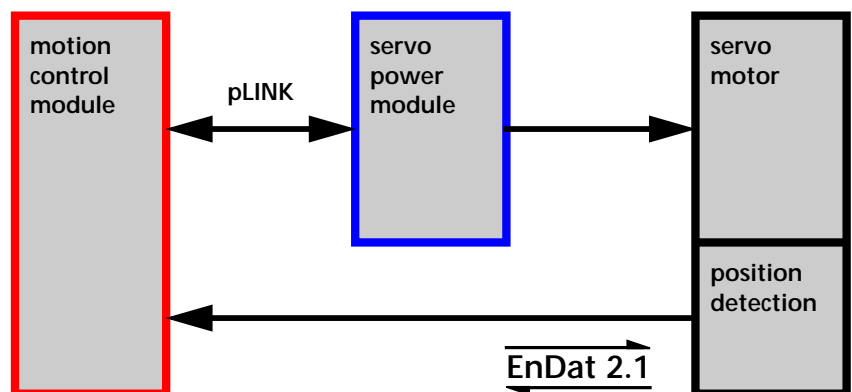

► Position detection with high-resolution EnDat 2.1 encoder

The MCE-8 motion control module uses an absolute encoder with EnDat 2.1 interface and additional sinusoidal incremental signals for position detection.

The motion control module's interpolation electronics allow one sine wave period to be subdivided into 200 measurement steps, thus enabling control to be performed at a very high level of precision.

The position information from the encoder is further refined by evaluating the sinusoidal signals to yield high-resolution absolute position information.

The encoder is connected directly on the motion control module. Connecting the encoder to the servo power module is not necessary, thus simplifying wiring.

Appropriate motion control modules are available for other position detection methods. They can be combined in any manner in multi-axes applications.

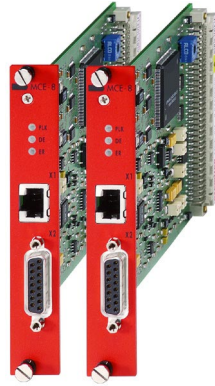

► Position command with control

Every motion-control module is equipped with a quick-reacting position command generator. This creates a sequence of time-equidistant high-resolution set points from the data for the prescribed run sequence (target position, velocity, acceleration, and jerk).

Together with the ultra-precision jerk control, this produces an especially harmonic motion profile which minimizes wear on the mechanical elements.

A special feature is that a motion will be started within one millisecond without any delay. In addition, velocity and target position can also be modified while a specific motion is still going on.

► Servo power modules

For motors of varying power there are different servo power modules available. They can be combined in any desired manner with the available motion control modules.

- **TrioDrive C**
Continuous current 2 to 6A_{rms}
Power supply 1 × 230V_{AC}
- **MidiDrive C**
Continuous current 2 to 20A_{rms}
Power supply 3 × 400/480V_{AC}



► Servo motors of any type

Since all the properties of the servo motor can be set digitally, the MCE-8 motion control module can control virtually any drive equipped with an encoder with EnDat 2.1 interface using sinusoidal incremental signals. This also includes AC servo motors, torque motors and rotational direct drives.

This means that for any given installation the most suitable motors can be selected and combined regardless of their respective manufacturers.

Technical specifications

EnDat 2.1 interface

Transmission method	Synchronous-serial
Electrical interface	RS422 (differential line driver)
Monitoring	Line break CRC-check Plausibility

Sinusoidal incremental signals

Transmission method	2-channel with 90° phase-shifted sinusoidal incremental signals
Electrical interface	1 V _{pp} (differential line driver)
Frequency	200 kHz
Interpolation	between 20 and 200 measurement steps per period, settable
Monitoring	Line break Amplitude Frequency
Speed	10 × 10 ⁶ measurement steps / second
Motor temperature monitoring	PTC with settable switching threshold