

# modular motion coordination

# SYSTEM-90E

➤ **A modular system with a minimum of diverse components**

This innovative system provides for a modular configuration of flexible multi-axis drive topologies without using a large number of different components.

➤ **Servo motors from 100W to 11kW**

The motion control system is designed to allow the most diverse types of motors to be directly driven. To accomplish this, servo power modules with a power rating of up to 11 kW are available.

➤ **Flexible position detection**

The motion control modules that best fit the position detection system used will be employed; they connect to the servo power module via the uniform pLINK interface.

➤ **Digital parameter setting**

SYSTEM-90E provides for parameter setting for the drives to be performed on a completely numerical basis.

This makes all settings absolutely repeatable, thus significantly facilitating commissioning and maintenance procedures.

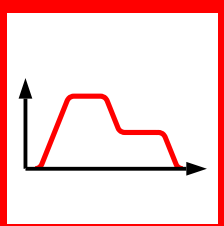

Motion control system for any type of servo motors

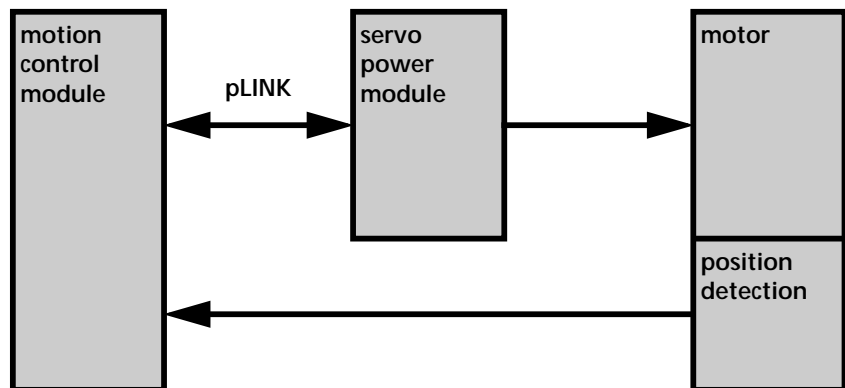



## ► pLINK interface

This interface serves to connect a motion control module to a servo power module.

Across this interface commands and set values are transmitted to the servo power module and at the same time the entire monitoring of the servo power module is performed via this interface.

Cost effective, pre-fabricated RJ45 cables are used for connection.



## ► Motors

The universal configuration of the motion control system allows servo motors of various designs to be combined and operated regardless of their respective manufacturers.

To accomplish this, just specify the respective motor configuration in the parameters.

- AC servo motors
- Linear motors
- Direct drives
- Torque motors
- Solenoid motors
- DC servo motors
- 2- and 3-phase motors
- 1 to 50 pole pairs



## ► Motion control module

This module is an integral part of SYSTEM-90E and serves to connect the respective position detection system employed.

In addition, this module is equipped with a pLINK interface for connecting to a servo power module. The pLINK interface has a uniform design which allows any servo power module to be directly connected.

## ► Position detection

Various methods of position detection can be employed by simply plugging in the appropriate motion control module.

- MCO-5**  
Incremental encoder using RS422 signals
- MCR-6**  
Resolver
- MCS-7**  
Incremental encoder using sinusoidal signals
- MCE-8**  
Absolute encoder with EnDat 2.1 interface using sinusoidal signals
- MCE-9**  
Absolute encoder with digital EnDat 2.2 interface
- MCB-10**  
Absolute encoder with digital BiSS interface
- HIPERFACE**

## ► Servo power module

The following servo power modules are available for motors of varying power:

- TrioDrive C**  
Continuous current 2A to 6A  
Power supply 1 × 230V<sub>AC</sub>
- MidiDrive C**  
Continuous current 2A to 20A  
Power supply 3 × 400/480V<sub>AC</sub>

All servo power modules can be used directly on the mains without necessitating either a series transformer or a separate line filter.



## ► Setting of parameters and performing diagnosis

The digital mode of operation allows all settings to be numerically specified which ensures absolute repeatability of the settings.

As the monitoring of the servo power module is performed via the pLINK interface, SYSTEM-90E provides integral system diagnostic capabilities ranging from the triggering of an alarm up to its recording in a logbook.

**promicon**  
SYSTEMS

D-72124 Pliezhausen  
Fon: + 49 (0) 7127 - 93730  
www.promicon.com